



VACUUM OVEN

MODEL: 1425, 1445 & 1465

INSTALLATION AND OPERATION MANUAL

Sheldon Manufacturing Inc. P.O. Box 627 Cornelius, Oregon 97113
EMAIL: tech@Shellab.com INTERNET: <http://www.Shellab.com/~Shellab>
1-800-322-4897 (503) 640-3000 FAX (503) 640-1366

TABLE OF CONTENTS

SECTION 1.0	RECEIVING AND INSPECTION
SECTION 2.0	GRAPHIC SYMBOLS
SECTION 3.0	INSTALLATION
SECTION 4.0	PRECAUTIONS
SECTION 5.0	CONTROL PANEL OVERVIEW
SECTION 6.0	VACUUM OPERATION
SECTION 7.0	OPERATION
SECTION 8.0	MAINTENANCE
SECTION 9.0	TROUBLESHOOTING
SECTION 10.0	PARTS LIST UNIT SPECIFICATIONS SCHEMATICS

REV 05/02
4861531

These units are general purpose vacuum ovens for professional, industrial or educational use where the preparation or testing of materials is done at approximately atmospheric pressure and no flammable, volatile or combustible materials are being heated. These units are not intended for hazardous or household locations or use.

SECTION 1

RECEIVING AND INSPECTION

IMPORTANT: READ THIS INSTRUCTION MANUAL IMMEDIATELY.

Your satisfaction and safety require a complete understanding of this unit, including its proper function and operational characteristics. Be sure operators are given adequate training before attempting to put unit in service. **NOTE: This equipment must be used only for its intended application; any alterations or modifications will void your warranty.**

- 1.1 Inspection:** The carrier, when accepting shipment, also accepts responsibility for safe delivery and is liable for loss or damage claims. On delivery, inspect for visible exterior damage. Note and describe on the freight bill any damage found and enter your claim on the form supplied by the carrier.
- 1.2** Inspect for concealed loss or damage on the unit itself, both interior and exterior. If any, the carrier will arrange for official inspection to substantiate your claim. Save the shipping crate until you are sure the unit has been delivered in good condition.
- 1.3 Return Shipment:** If for any reason you must return the unit, contact your VWR representative for authorization. Supply the complete data plate information when requesting return authorization. Please see the manual cover for information on where to contact customer service.
- 1.4 Accessories:** Verify that all of the equipment indicated on the packing slip is included with the unit. Carefully check all packaging before discarding. The model 1425 is equipped with two (2) deep shelves and one (1) shallow shelf. The model 1445 is equipped with two (2) deep shelves, one (1) shallow shelf and four (4) adjustable feet. The model 1465 is equipped with three (3) shelves and four (4) adjustable feet.

SECTION 2

GRAPHIC SYMBOLS

Your oven has been provided with a display of graphic symbols which should help in identifying the use and function of the available user adjustable components.

2.1.  Indicates "AC Power On".

2.2.  Indicates "Manual Adjust".

2.3.  Indicates "Temperature".

2.4.  Indicates "Over Temperature Safety".

2.5.  Indicates "Vacuum Gauge".

2.6.  Indicates "Consult Your Manual".

2.7.  Indicates "Vent Valve".

SECTION 3

INSTALLATION

Local city, county, or other ordinances may govern the use of this equipment. If you have any questions about local requirements, please contact the appropriate local agency. Installation may be performed by the end user.

Under normal circumstances these units are intended for use indoors, at room temperatures between 5° and 40°C, at no greater than 80% relative Humidity (at 25°C) and with a supply voltage that does not vary by more than 10%. These ovens should not be operated at an altitude exceeding 2000 meters. Installation category is CAT-II Pollution Degree 2. Customer service should be contacted for operating conditions outside of these limits.

- 3.1 Power Source:** The unit power requirements are listed on the data plate. **PLUG THE UNIT INTO A PROPERLY GROUNDED AND RATED RECEPTACLE OF THE CORRECT STYLE. THE VOLTAGE OF THE RECEPTACLE SHOULD NOT VARY MORE THAN 10% FROM THE DATA PLATE RATING.** A separate circuit is recommended for this unit to prevent loss of product due to overloading or circuit failures caused by other equipment.
- 3.2 Location:** When selecting a site for the unit, consider conditions which may affect performance, such as heat from radiators, ovens, autoclaves, etc. Avoid direct sun, fast-moving air currents, heating/cooling ducts, and high-traffic areas. To ensure air circulation, allow a minimum of 15cm between the unit and any walls or partitions which might obstruct free air flow.
- 3.3 Lifting / Handling:** These units are heavy and care should be taken to use appropriate lifting devices that are sufficiently rated for these loads. Units should only be lifted from their bottom surfaces. Doors, handles and knobs are not adequate for lifting or stabilization. The unit should be completely restrained from tipping during lifting or transport. All moving parts such as shelves and trays should be removed and doors need to be positively locked in the closed position during transfer to prevent shifting and damage.
- 3.4 Leveling:** The unit must sit level and solidly. Model 1425 has four (4) rubber feet that are already attached to the unit and are not adjustable. Leveling feet are supplied with models 1445 and 1465 and must be installed in the four holes at the base of the unit. With the unit standing upright, turn the leveling feet counterclockwise to raise the level of that corner. Adjust each foot until the unit stands solid and level. If the unit must be moved, turn the leveling feet in all the way to prevent damage while moving.

3.5 Cleaning: The oven was cleaned at the factory, but not sterilized. Remove all interior parts and clean the inside of the chamber, thoroughly with a solution that is appropriate for your application. **DO NOT USE** chlorine-based bleaches or abrasives as this will damage the stainless steel chamber. **DO NOT USE** spray cleaners that might leak through openings and cracks and get on electrical parts or that may contain solvents that will harm the coatings. Periodic cleaning is strongly recommended.

WARNING: Never clean the unit with alcohol or flammable cleaners with the unit connected to the electrical supply. Always disconnect the unit from the electrical service when cleaning and assure all volatile or flammable cleaners are evaporated and dry before reattaching the unit to the power supply.

3.6 Shelves: See Figure below. Place items on shelves. **DO NOT** place items directly on the floor of the chamber.

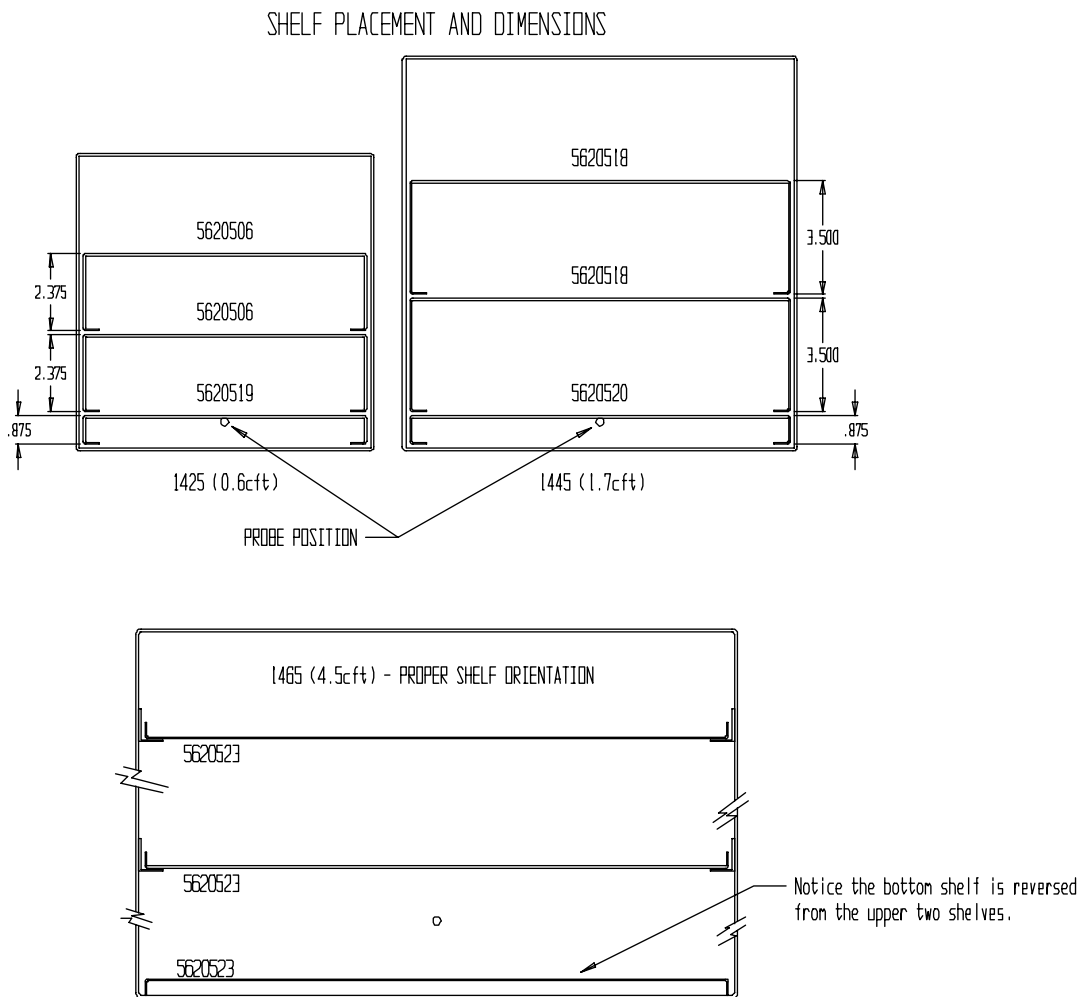

SECTION 4

PRECAUTIONS

NOTE: THIS IS NOT AN EXPLOSION PROOF OVEN

- 4.1 Do not place or use explosive, combustible, or flammable materials in the oven.
- 4.2 Do not use sealed containers in the oven chamber.
- 4.3 Do not cut or remove the ground prong, if present, from the power cord or use an ungrounded adapter plug.
- 4.4 Disconnect the unit from the electrical power source before attempting any repairs or component replacements.
- 4.5 If a mercury thermometer is used and breakage should occur, make sure **all** the spilled mercury is removed from the chamber.
- 4.6 This oven is **NOT** suitable for use in Class I, II, or III locations as defined in the National Electric Code of the United States of America, NFPA 70.
- 4.7 This oven is not intended, nor can it be used, as a patient connected device.

SECTION 5

CONTROL PANEL OVERVIEW (Figure 2)

- 5.1 **POWER SWITCH:** This is the main power I/O (On/Off) switch. It must be in the ON position before any systems are operational.
- 5.2 **MAIN TEMPERATURE CONTROL:** This is the Main Temperature control consisting of the digital display and UP/DOWN arrow pads for adjusting set point temperatures and calibration.
- 5.3 **HEATING LIGHT:** This green indicator light is on whenever the MAIN TEMPERATURE CONTROL has activated the heating elements to reach and maintain set point.
- 5.4 **CIRCUIT BREAKER/FUSE:** This control is completely independent of the MAIN TEMPERATURE CONTROLLER and guards against any failure which would allow temperature to rise past the Temperature set point. Setting adjustments for this control require a flat-edged tool to eliminate accidental changes. The control has a dial that is marked from 0 to 10 and is adjustable across this scale. If the set point is exceeded, the Circuit Breaker/Fuse will limit the rise to approximately 10°C above the set point selected.
- 5.5 **OVER TEMPERATURE LIGHT:** This red indicator light is on whenever the temperature has exceeded the set point of the MAIN TEMPERATURE CONTROL and the CIRCUIT BREAKER/FUSE is activated and taken control of the oven. Under normal operating conditions this pilot light should never be on.
- 5.6 **FUSE:** This control, mounted on the rear wall next to the power cord, provides protection for the unit's electrical circuitry against power fluctuations. The fuse, when blown, must be replaced before the unit can continue operation.
- 5.7 **VACUUM:** This adjustment handle allows opening and closing of the vacuum valve to an external vacuum pump or system.
- 5.8 **VENTILATION:** This adjustment handle controls the vacuum release valve. This valve must be closed (completely clockwise) when the unit is in the vacuum mode.
- 5.9 **VACUUM GAUGE:** This gauge indicates the chamber operating pressure in millibars.

Figure 2

1425

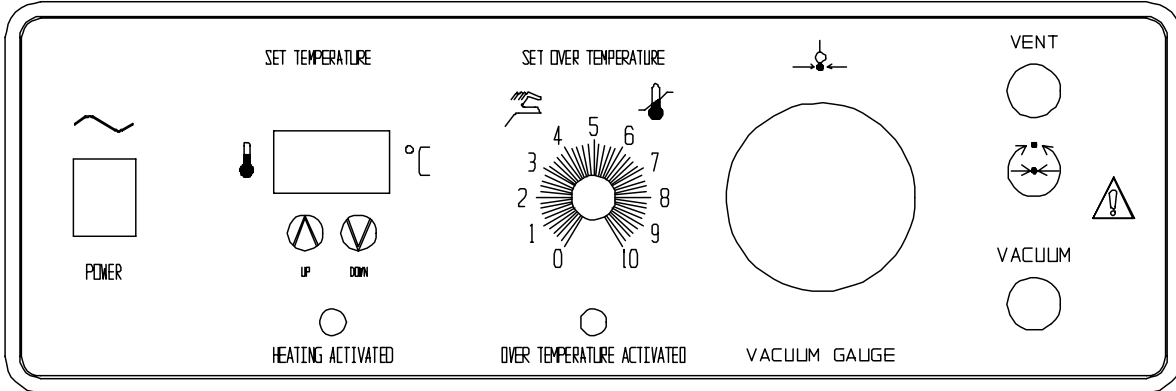

4500868

1445 & 1465

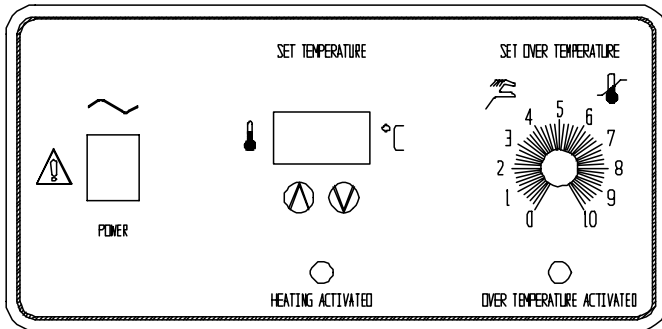

4500869

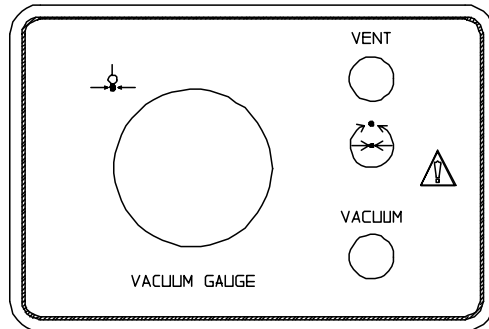

4500870

SECTION 6

VACUUM OPERATION

- 6.1 A pump with a pumping capacity four times greater than the chamber volume is commonly used. When working below vacuums of 1mm, a diffusion type pump will be needed. See Section 9.0 for chamber capacities
- 6.2 **IT IS IMPORTANT TO USE VACUUM TUBING FOR ALL THE VACUUM HOOKUPS. OTHER TYPES OF TUBING MAY COLLAPSE AND PREVENT COMPLETE EVACUATION.**
- 6.3 **To Apply Vacuum To The Chamber:** Attach the hose from the vacuum pump to the 3/8" hose connection on back of the oven. Close the VENTILATION valve (clockwise) and open the VIDE valve. Latch the door shut and start the vacuum pump. This action will hold the door shut and against the gasket until the pump creates a vacuum in the chamber. Once a good vacuum seal is accomplished, the door will hold itself shut and sealed until the chamber is returned to atmospheric pressure.
- 6.4 Watch the **VACUUM GAUGE** and when the required vacuum is obtained, close the VACUUM valve and turn pump off. The VACUUM GAUGE is calibrated from 1 to 900 millibars with 1013 millibars representing atmospheric pressure. The oven can be evacuated to pressures as low as 10 microns.
- 6.5 **Vacuum Release:** To return the chamber to atmospheric pressure, open the VACUUM valve very slowly and allow the chamber to re-pressurize. The speed of pressurizing can be controlled by how much the valve is opened.

NOTE: A 1 inch sealed pipe is provided at the back of the unit. This access port can be used to plumb the chamber to a larger, faster roughing pump or as a conduit for other service applications. Any use of this pipe requires the operator to assure the attachment is vacuum tight.

SECTION 7

OPERATION

- 7.1 Power Supply:** Connect the service cord to a grounded outlet and switch unit to the ON position. If supplied with a detachable cord set, plug the female end into the inlet of the unit and the male end into the supply. Assure that units requiring a fuse have a fuse installed. This fuse may be at the inlet or part of the cord set male plug.
- 7.2** Turn the Circuit Breaker/Fuse control to its maximum position (clockwise).
- 7.3** Place a certified reference thermometer inside the chamber where it can be easily viewed through the window. Vacuum down the chamber as described in Section 5.0
- 7.4 Setting Main Temperature:** To enter set point mode on the control, press either the UP or DOWN arrow pad one time. The digital display will start to blink from bright to dim. While blinking, the digital display is showing the set point. To change the set point, use the Up or Down arrow pads. If the arrow pads are not pressed for five (5) seconds, the display will stop blinking and will read the temperature of the unit. The Heating Light Cycle light will come on indicating that the oven is heating. Allow the unit several hours to reach and maintain set point
- 7.5 Calibrating the Main Temperature:** It is recommended that calibration is done once the unit is installed in its working environment and has been stable at set point for several hours. Compare the reading of the reference thermometer with the digital display. If there is an unacceptable difference, put the display into calibrate mode by pressing both the UP and DOWN buttons at the same time until the decimal points start to blink. While blinking, the display can be changed to match the reference thermometer by pushing the UP or DOWN buttons until the display reads the correct value. If no buttons are pushed for five (5) seconds the display will revert back to reading the temperature in the chamber. Allow for the oven temperature to stabilize again and recalibrate if necessary.
- 7.6 Setting the Circuit Breaker/Fuse:** Once the Main Temperature is stable at set point, set the Circuit Breaker/Fuse control. Previously set to its maximum position, turn the control knob counterclockwise just until the OVER TEMPERATURE LIGHT comes on. Next turn the control knob clockwise just until the light goes off. Then turn the control knob clockwise two (2) minor scale divisions on the dial past the point where the light went out. The Circuit Breaker/Fuse control will now be set approximately 10°C above the Main temperature set point.

When starting a new oven, allow the oven to operate two hours, or until it has started cycling normally before you begin using it.

NOTE: Slight vapor or smoke may occur in the initial heat-up. This is the dissipation of protective coatings that have been added to the oven elements.

SECTION 8

MAINTENANCE

NOTE: Prior to any maintenance or service on this unit, disconnect the service cord from the power supply.

- 8.1 Cleaning:** Disinfect the oven interior on a regular basis. To prepare the oven for cleaning remove the shelves and door gasket. The shelves and door gasket are autoclavable. When washing the gasket, handle carefully so as not to impair the positive seal.

First, clean the removed parts and interior with soap and water. To decontaminate use a disinfectant that is suitable for your application. **DO NOT USE** chlorine-based bleaches or abrasives as this will damage stainless steel surfaces. **DO NOT USE** spray cleaners that might leak through openings and cracks and get on electrical parts or that may contain solvents that will harm the coatings.

WARNING: Never clean the unit with alcohol or flammable cleaners with the unit connected to the electrical supply. Always disconnect the unit from the electrical service when cleaning and assure all volatile or flammable cleaners are evaporated and dry before reattaching the unit to the power supply.

- 8.2 Storage:** if the oven is to be shut down for storage or transporting, remove shelves, dry chamber and latch door closed. Screw the leveling feet in. See Section 2.3 for transport procedures.
- 8.3** There is no maintenance required on the electrical components. If the oven fails to operate as specified, see troubleshooting before calling for service.

SECTION 9

TROUBLESHOOTING AND SERVICE

TEMPERATURE

Temperature too high

- 1/ controller set too high-see SECTION 6.4
- 2/ controller failed on – call Customer Service
- 3/ wiring error – call Customer Service

Display reads "HI" or "400"+

probe is unplugged, is broken or wire to sensor is broken – trace wire from display to probe; move wire and watch display to see intermittent problems

Chamber temperature spikes over set point and then settles to set point

recalibrate – see section 6.5

Temperature too low

- 1/ Controller set too low – see section 6.6
- 2/ Main control set too low – see section 6.4
- 3/ unit not recovered from door opening – wait for display to stop changing
- 4/ unit not recovered from power failure or being turned off
- 5/ element failure – see if Heating light is on; compare current draw to data plate
- 6/ Main controller failure – confirm with front panel lights that controller is calling for heat
- 7/ Controller failure – confirm with front panel lights that circuit breaker/fuse is operating correctly
- 8/ wiring problem – check all functions and compare wiring to wiring schematic in manual - especially around any areas recently worked on
- 9/ loose connection – check shadow box for loose connections

Display reads "LO"

- 1/ Main sensor is plugged in backwards – reverse sensor wires to controller
- 2/ if ambient room temperature is lower than range of unit – compare set points and ambient temperature to rated specifications in section 9.0, Unit Specifications

Unit will not heat over a temperature that is below set point

- 1/ confirm that Controller set point is set above the Main Temperature set point and that the reset switch has not been activated
- 2/ check connections to sensor

3/ check calibration – using independent thermometer, follow instructions in section 6.5

Unit will not heat up at all

1/ verify that controller is asking for heat by looking for Heating light – if pilot light is not on continuously during initial start up, there is a problem with the controller
2/ check amperage – amperage should be virtually at maximum rated (data plate) amperage
3/ do all controller functions work?
4/ is the Controller set high enough? – for diagnostics, should be fully clockwise with the Over Temperature light never on
5/ has the fuse blown? Check fuse at inlet.
6/ Units will need at least some vacuum in chamber to keep unit air tight - verify with Vacuum Gauge is above “0”

Indicated chamber temperature unstable

1/ ± 1 . may be normal
2/ is ambient room temperature radically changing – either door opening or room airflow from heaters or air conditioning ? – stabilize ambient conditions
3/ sensor miss-located, damaged or wires may be damaged - check mounts for Main and Controller sensors, then trace wires or tubing between sensors and controls
4/ calibration sensitivity – call Customer Service
5/ Controller set too low – be sure that it is more than 5 degrees over desired set point; check if Over Temperature light is on continuously; turn controller knob completely clockwise to see if problem solved then follow instructions in section 6.6 for correct setting
6/ electrical noise – remove nearby sources of RFI including motors, arcing relays or radio transmitters
7/ bad connection on temperature sensor or faulty sensor – check connectors for continuity and mechanical soundness while watching display for erratic behavior; check sensor and wiring for mechanical damage
8/ bad connections or faulty solid state relay – check connectors for mechanical soundness and look for corrosion around terminals or signs of arcing or other visible deterioration

Will not maintain set point

1/ assure that set point is at least 5 degrees over ambient room temperature
2/ see if ambient room temperature is fluctuating

Display and Reference thermometer don't match

1/ calibration error – see section 6.6
2/ Main temperature sensor failure – evaluate if Heating light is operating correctly
3/ Main controller failure – evaluate if Heating light is

operating correctly
4/ allow at least two hours to stabilize
5/ verify that reference thermometer is certified

Can't adjust set points or calibration

1/ turn entire unit off and on to reset
2/ if repeatedly happens, call Customer Service

Calibrated at one temperature, but not at another

This can be a normal condition when operating temperature varies widely. For maximum accuracy, calibration should be done as close to the set point temperature as possible.

MECHANICAL

Glass door not sealing

1/ check physical condition of gasket
2/ assure that gasket clamps are in original location

Outer door not sealing

1/ see if hinges are out of adjustment
2/ Confirm that unit has not been damaged and body is not out of square.

Oven won't hold vacuum

1/ check door gasket for alignment and damage, wear or lack of compliance
2/ assure all vent and feed valves are closed tightly
3/ assure tight connections to pump

OTHER

controller on at all times - "locked-up"

1/ turn unit off and on to reset
2/ if cannot change any condition on the front panel, call Customer Service

front panel displays are all off

1/ check connections to the temperature display control board and assure that all are tight and in the correct orientation.
2/ Check for wire damage.

unit or wall fuse/circuit breaker is blown

1/ check wall power source
2/ compare current draw and compare to specs on data plate
3/ see what other loads are on the wall circuit

unit will not turn on

1/ check wall power source
2/ check fuse/circuit breaker on unit or in wall
3/ see if unit is on, e.g., heater, and just controller is off
4/ check all wiring connections, esp. around the on/off

switch.

Unit is smoking – Out of box

This is not uncommon during initial operation. Put unit under vent and run at full power for one hour.

Contamination in chamber

- 1/ see cleaning procedure in operator's manual
- 2/ develop and follow standard operating procedure for specific application; include definition of cleaning technique and maintenance schedule

If this product should require service, contact your local Shellab distributor. If return of the product be necessary, an authorization number must be obtained and the product shipped according to your representative, to the proper service center. To insure prompt handling, the return authorization number should be placed on the outside of the package or container. Make sure a detailed explanation of the reason for return is enclosed with the item.

SECTION 10

PARTS LIST

Description	115V	220V
Controller knob	4450506	4450506
Circuit Breaker, 15A	N/A	1100505
Outer Door Glass 1425	3550522	3550522
1445	3550521	3550521
1465	3550523	3550523
Door Glass 1425	700027	700027
1445	110107	110107
1465	3550586	3550586
Elements 1425 / 1445	9570741	9570786
1465 upper lower	9570740	9570740
1465 sides	9570729	9570729
EMI Filter, 10 AMP	N/A	2800502
Fuse, 10 AMP	3300502	N/A
Fuse, 6.3 AMP - 250V	N/A	103555
Fuse Holder	3300501	N/A
Inner Door Gasket 1425	3450508	3450508
1445	3450509	3450509
1465	3450510	3450510
Outer Door Gasket	600002	600002
I/O Switch	103351	103351
Pilot Light, green	200021	200021
Pilot Light, red	200020	200020
Power Cord	1800516	X1000778
RTD / Probe	103070	103070
Safety Controller	1750648	1750648
Solid State relay	101168	101168
Temperature Controller	1750607	1750607
Vacuum Gauge	9990618	9990618
Ventilation Valve	8600531	8600531
Vacuum Valve	8600531	8600531

UNIT SPECIFICATIONS

Weight	Shipping	Net
1425	145 lbs.	105 lbs.
1445	220 lbs.	179 lbs.
1465		

Dimensions	Exterior W x D x H (in.)	Interior W x D x H (in.)
1425	17 x 22.3 x 23.5	9 x 12 x 9
1445	20.5 x 28.2 x 26.25	12 x 20 x 12
1465		18 x 24 x 18

Capacity	Cubic Feet
1425	0.6
1445	1.7
1465	4.5

Temperature	Range	Sensitivity
1425 1445 1465	Amb. +5° to 240°C	1.0°C

MODEL	VOLTS	AMPS	VA	CYCLE
1425	120V AC	4.3	500	50/60hz
	220V AC	2.3	500	50/60hz
1445	120V AC	8.7	1000	50/60hz
	220V AC	4.5	1000	50/60hz
1465	120V AC	13	1500	50/60hz
	220V AC	6.8	1500	50/60hz

WIRE DIAGRAM

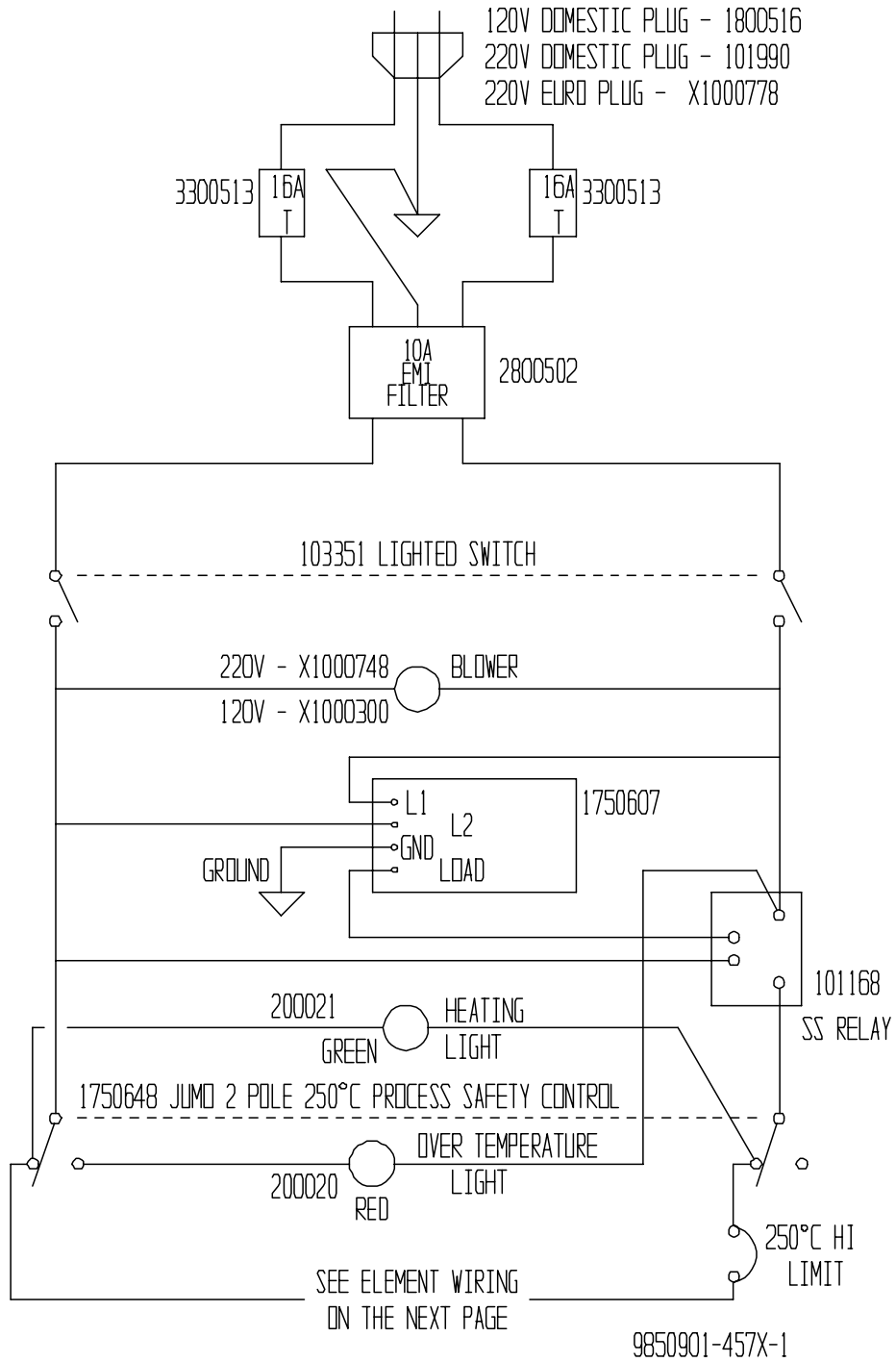

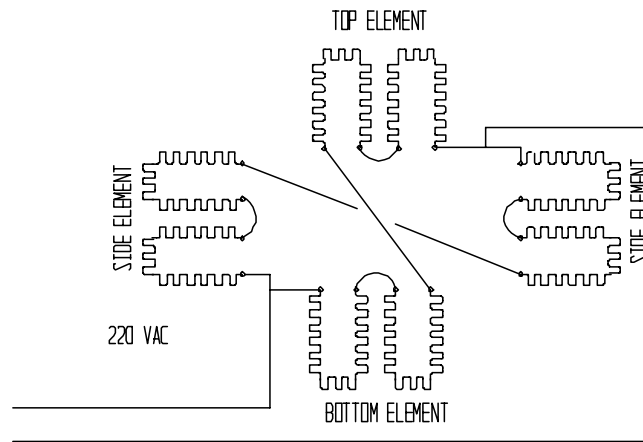
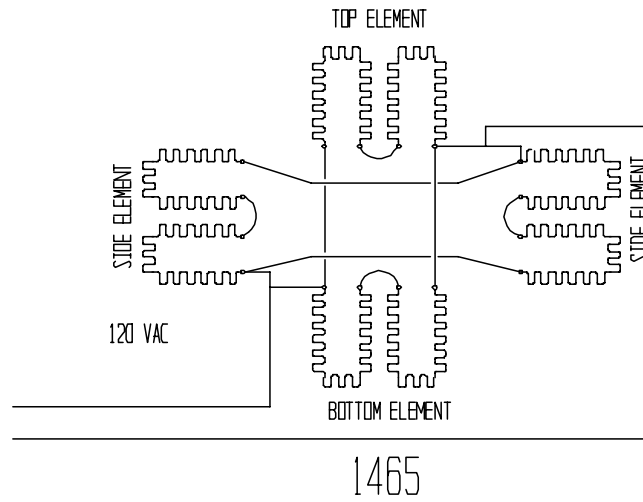
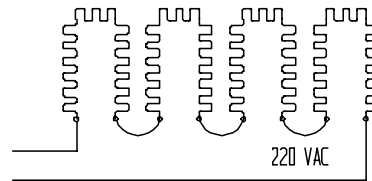
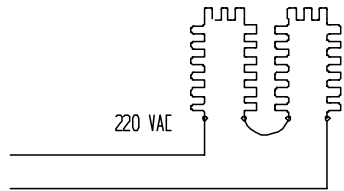
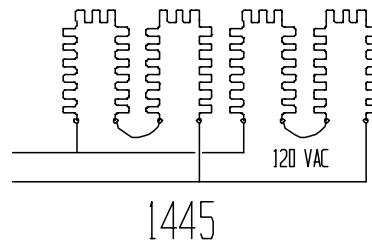
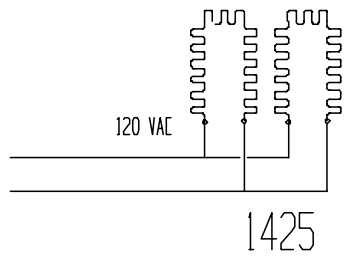

9850901-1425~1465